

Cursive Handwriting

Capital Letters - H.W.T.

NAME: _____



A is a

Name: _____

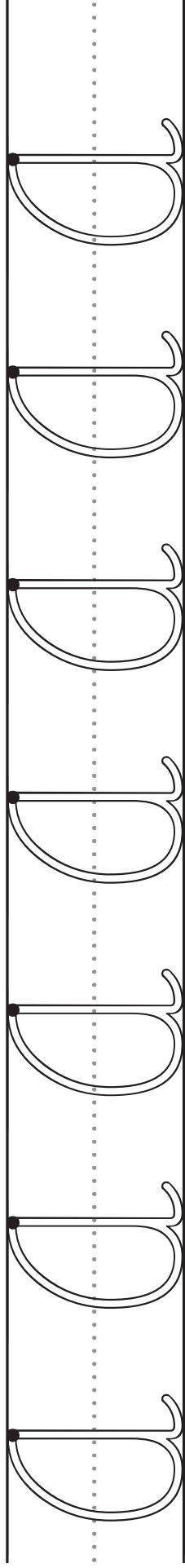
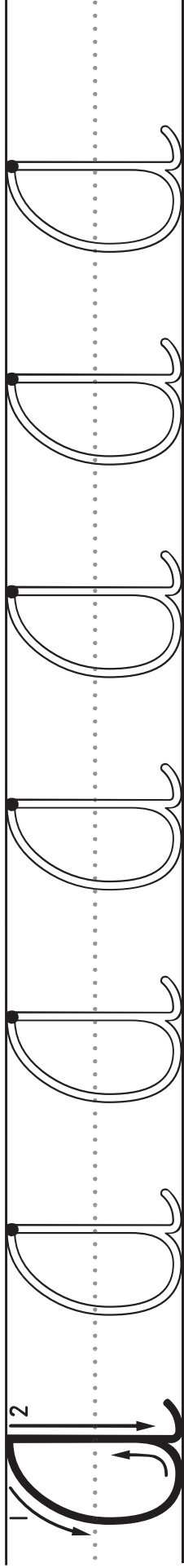

Teacher check:

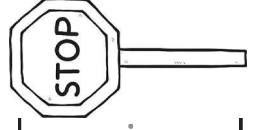

curative A:

B is B

Name: _____

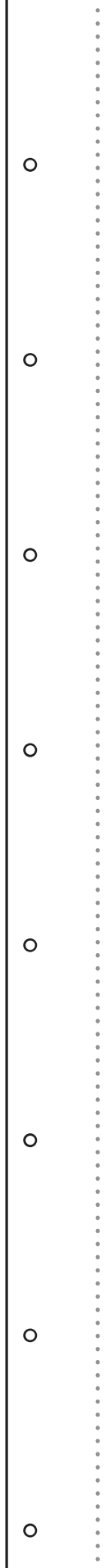
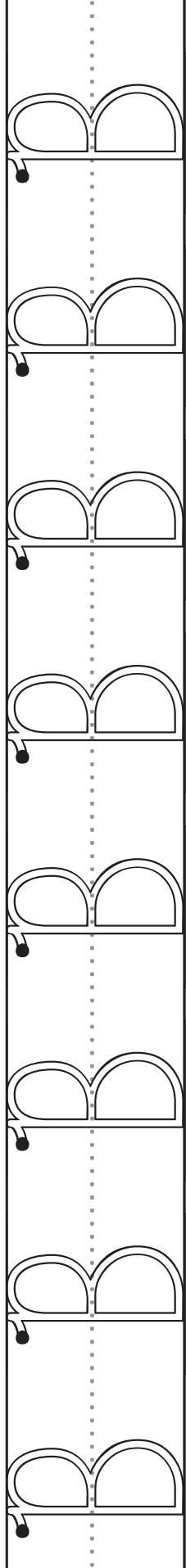
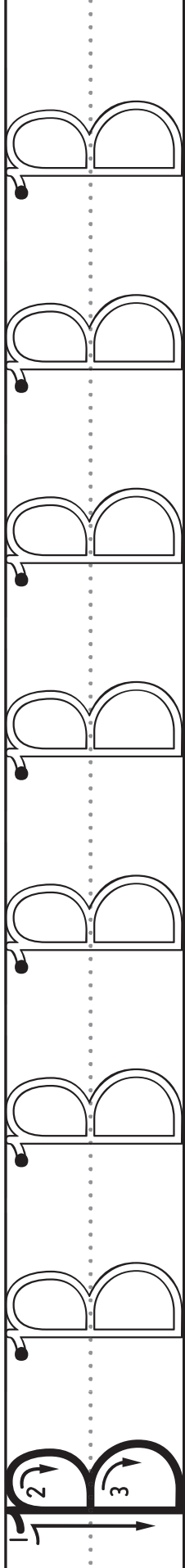

teacher check: _____

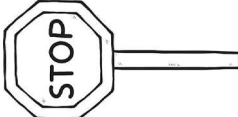

cursive B:

C i s C

Name: _____

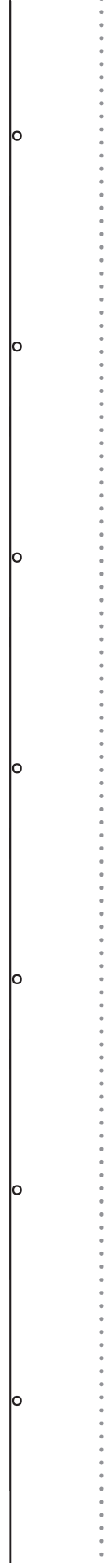
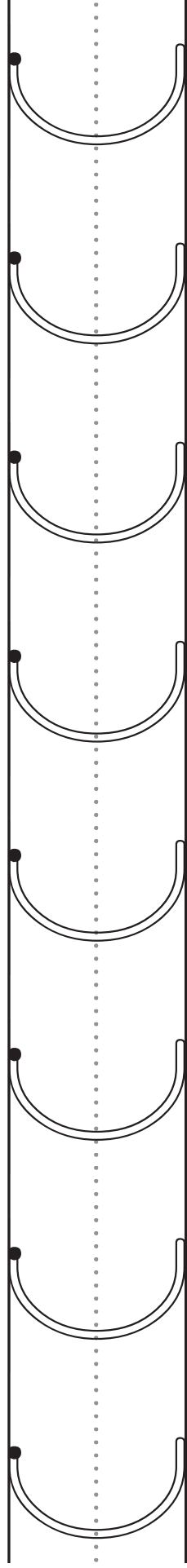
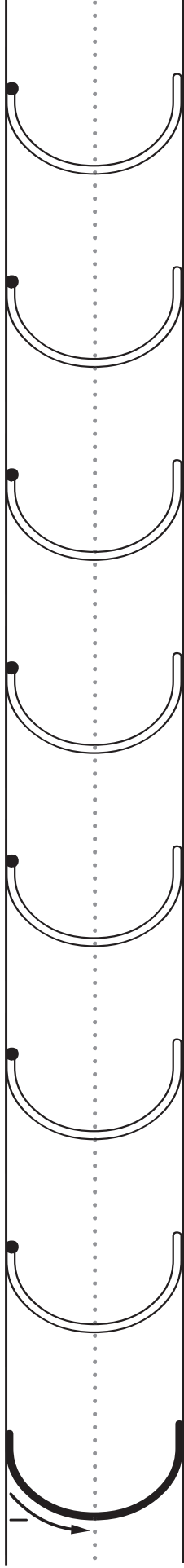

teacher check:

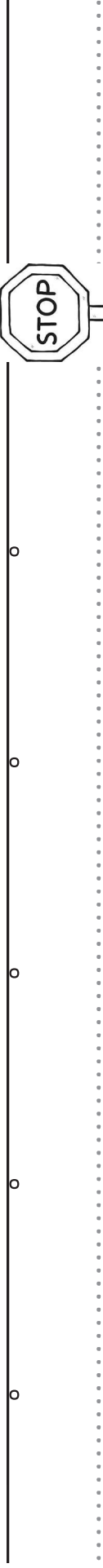
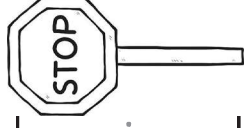

curative C:

D is D

Name: _____

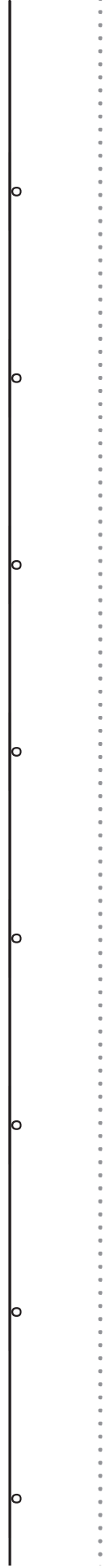
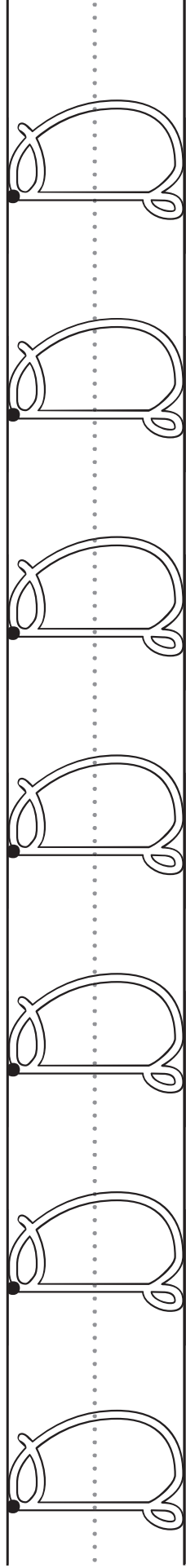
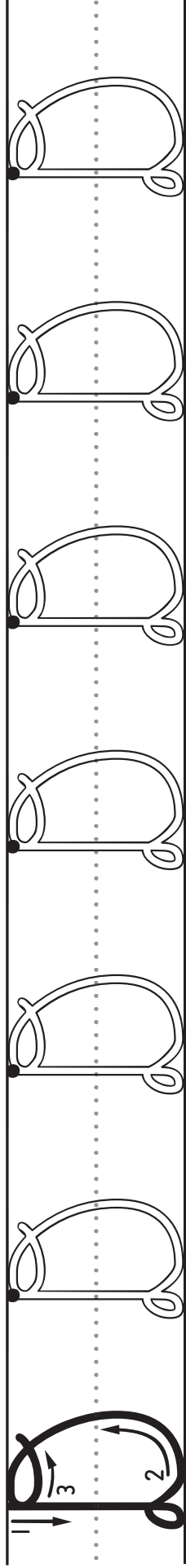

Teacher check:

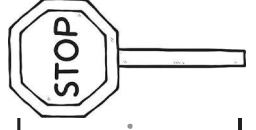

Curative D:

E i s 3

Name: _____

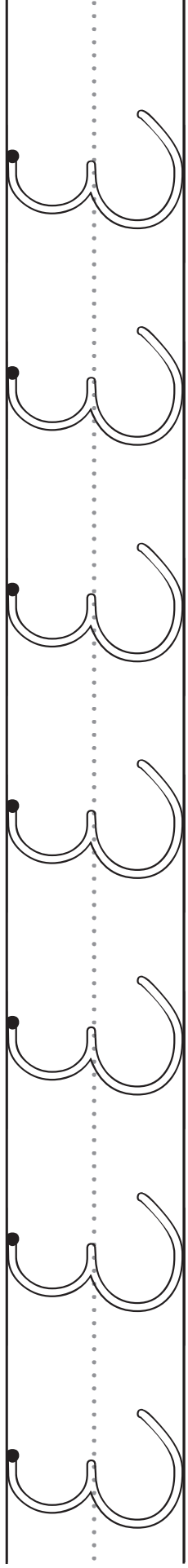
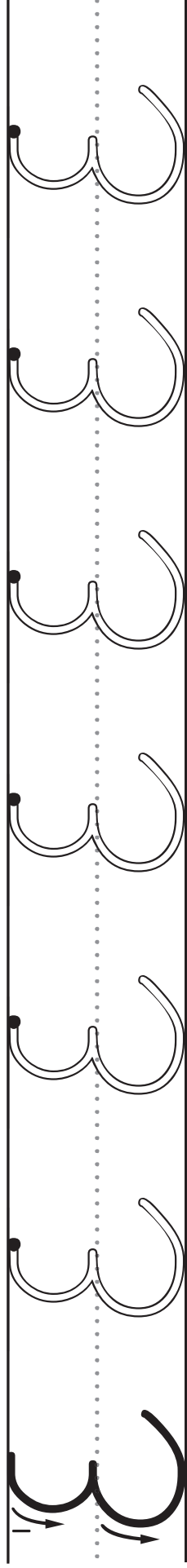

Teacher check: _____

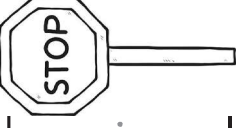

cursive E:

F i s j

Name: _____

Tracing guide for cursive 'f' showing stroke order: 1 (downward curve) and 2 (upward crossbar).

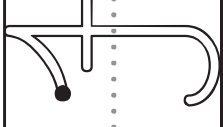
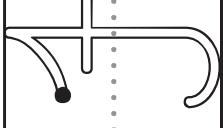
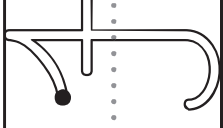

Tracing guide for cursive 'f' showing stroke order: 1 (downward curve) and 2 (upward crossbar).

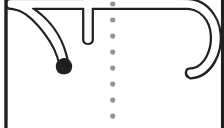
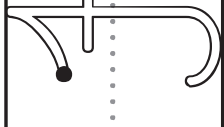
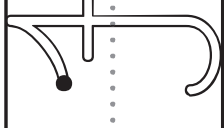

teacher check: _____

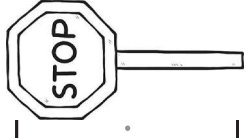

cursive F:

G is D

Name: _____

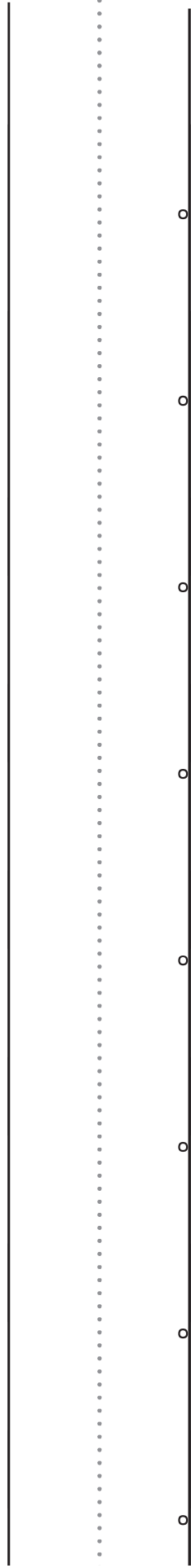
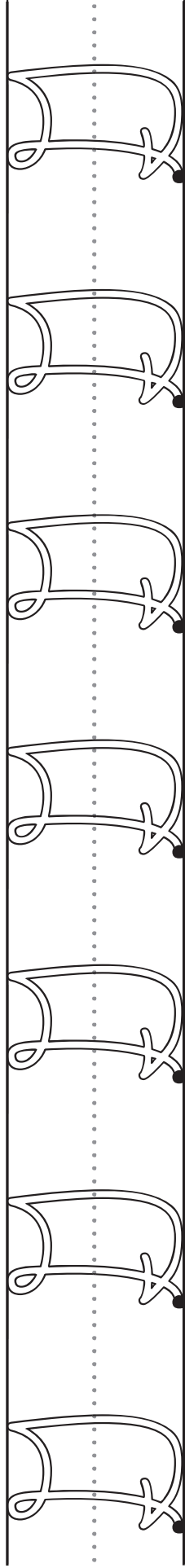
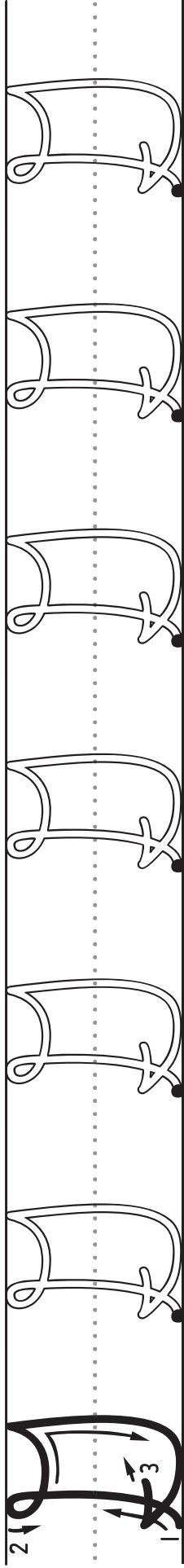

Teacher check:

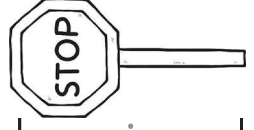

curative G:

H i s H

Name: _____

Handwriting practice row 1: A set of four-line guides with a dashed midline. The first cell shows a large uppercase 'H' with numbered arrows (1, 2, 3, 4) indicating stroke order: 1. vertical down on the left, 2. vertical down on the right, 3. top curve from left to right, 4. bottom curve from left to right. The following seven cells each contain a musical note on the bottom line and a cursive uppercase 'H' on the top line.

Handwriting practice row 2: A set of four-line guides with a dashed midline. The first cell contains a musical note on the bottom line and a cursive uppercase 'H' on the top line. The following seven cells each contain a musical note on the bottom line and a cursive uppercase 'H' on the top line.

Handwriting practice row 3: A set of four-line guides with a dashed midline. The first cell contains a musical note on the bottom line and a small circle on the top line. The following seven cells each contain a small circle on the top line.

teacher check:

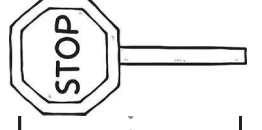

Handwriting practice row 4: A set of four-line guides with a dashed midline. The first cell contains a musical note on the bottom line and a small circle on the top line. The following seven cells each contain a small circle on the top line.

cursive H:

I i s l

Name: _____

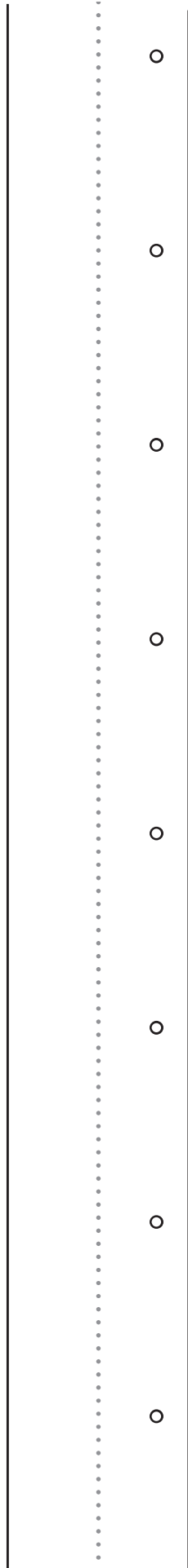
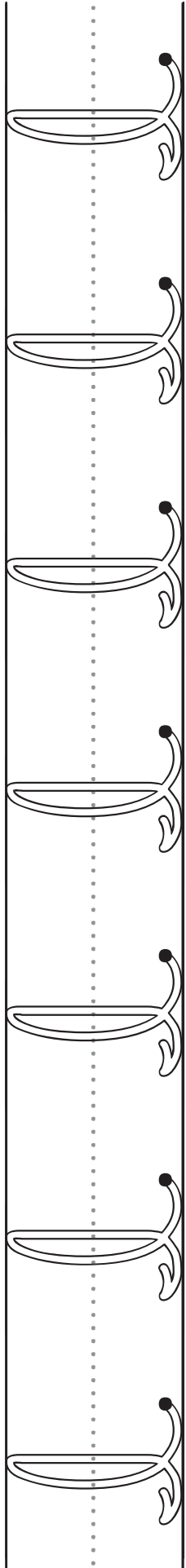
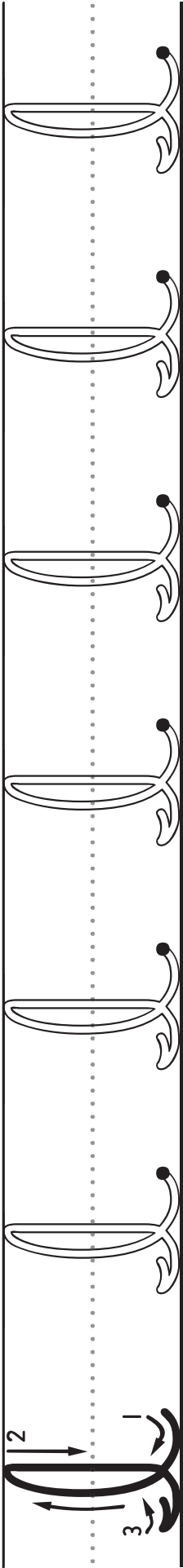

teacher check:

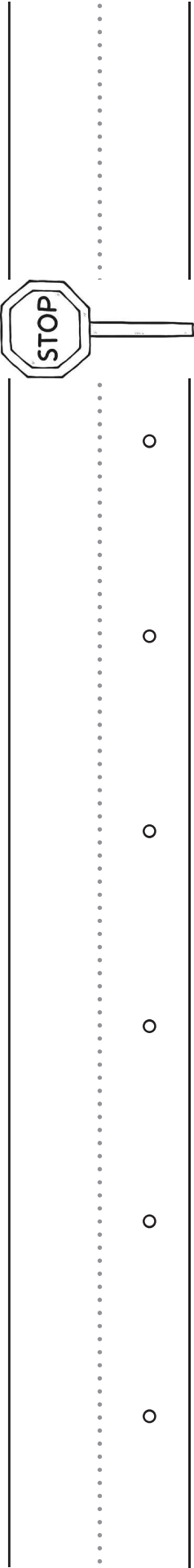
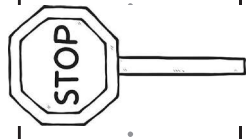

cursive l:

J is j

Name: _____

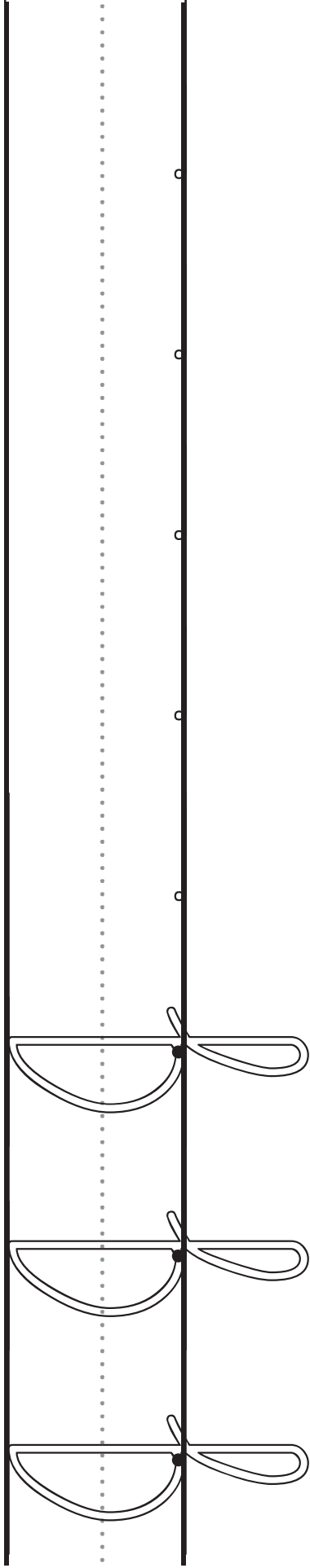
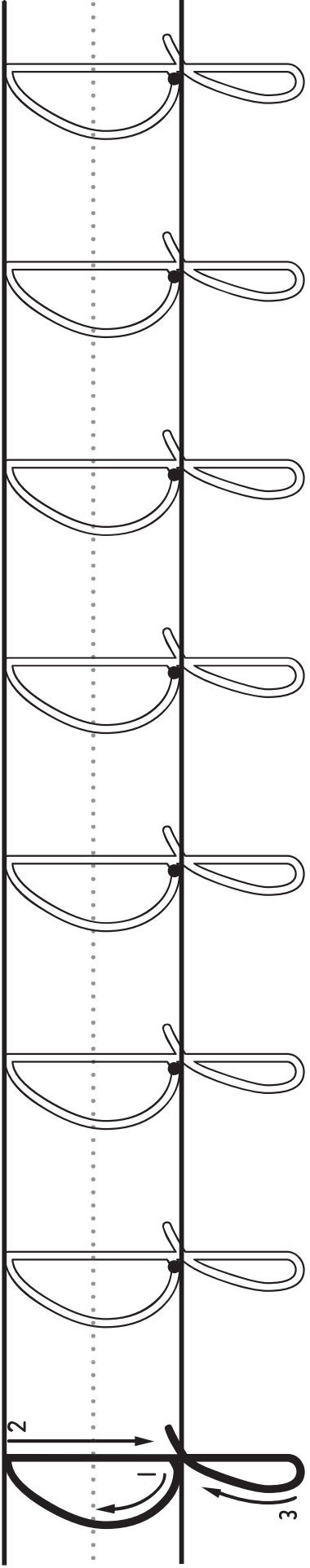

Teacher check:

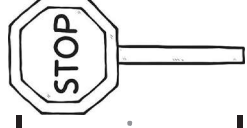

curious J:

K i s K

Name: _____

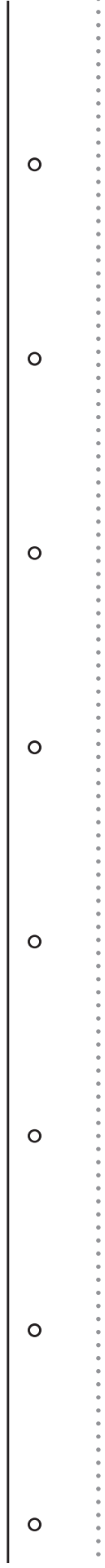
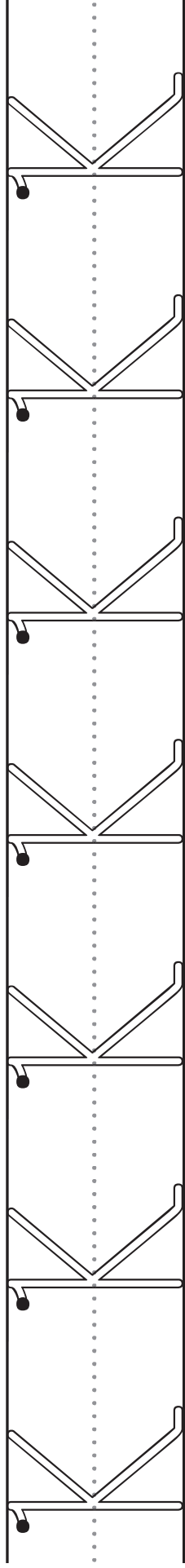
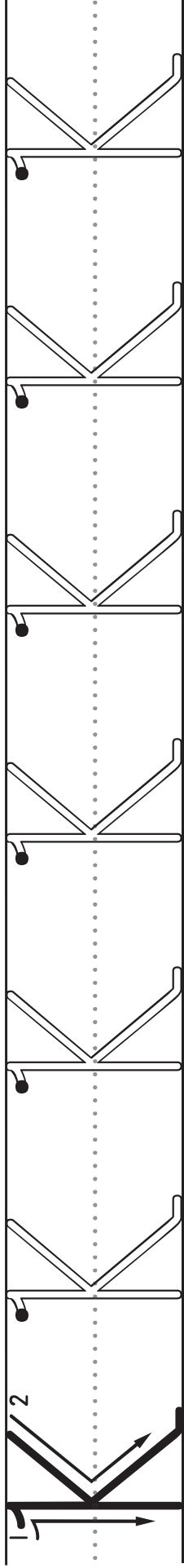

Teacher check: _____

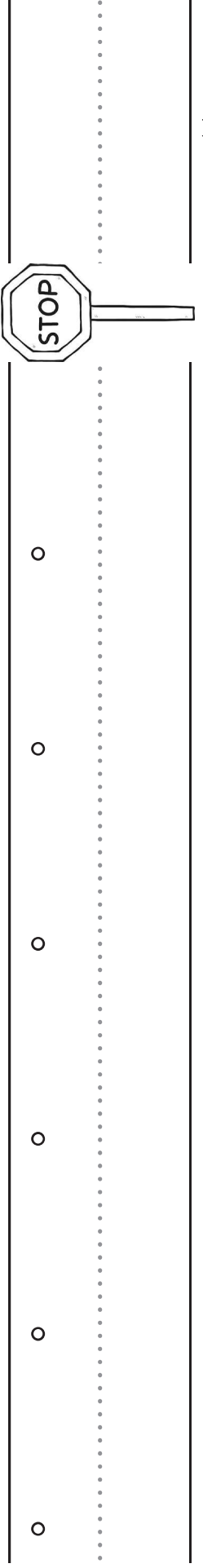
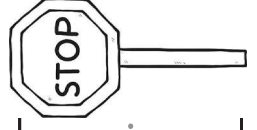

curative K:

L i s l

Name: _____

Tracing guide for cursive 'l' with stroke order arrows and numbers 1, 2, 3. Below are two rows of cursive 'l' characters for tracing, each with a starting dot and a dotted midline.

Two rows of cursive 'l' characters for tracing, each with a starting dot and a dotted midline.

Two rows of cursive 'l' characters for tracing, each with a starting dot and a dotted midline.

Teacher check section. It includes a 'STOP' sign icon, a dotted line for writing, and a box for the teacher's signature.

M i s m

Name: _____

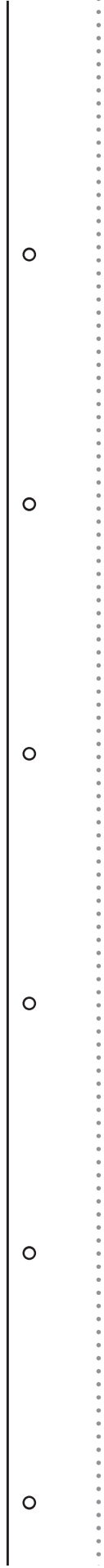
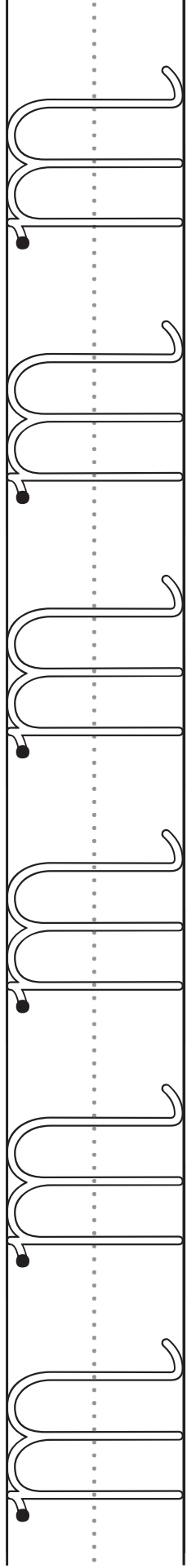
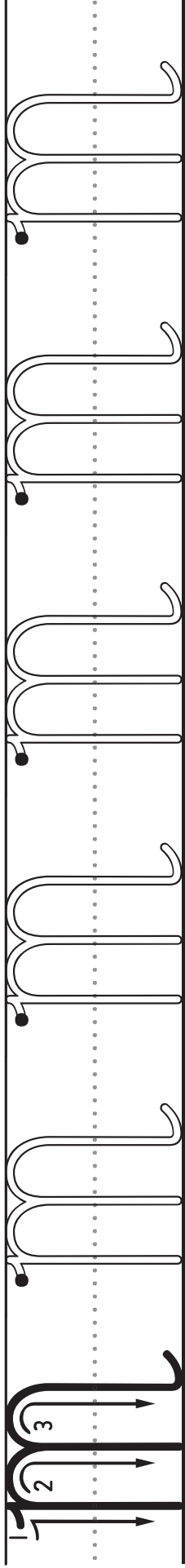

teacher check:

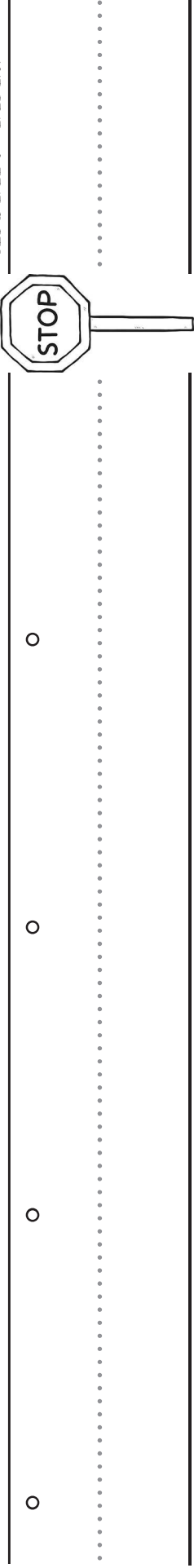
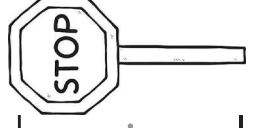

curative M:

N i s n

Name: _____

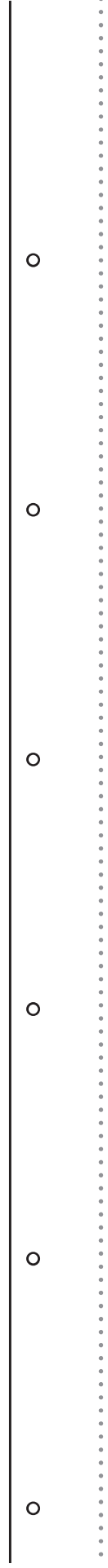
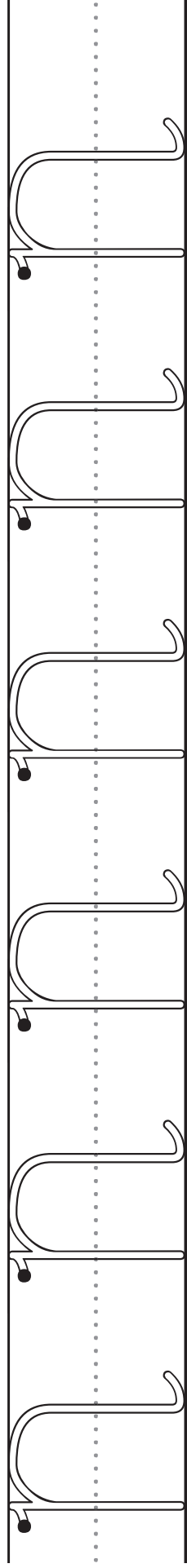
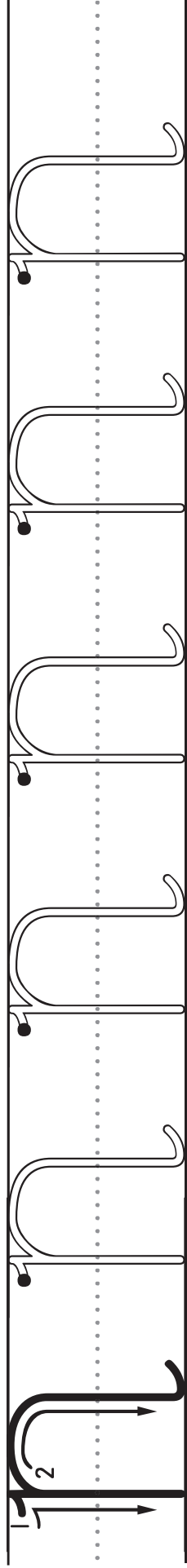

Teacher check:

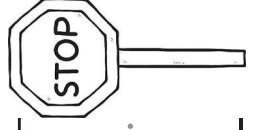

Curative N:

O is O

Name: _____

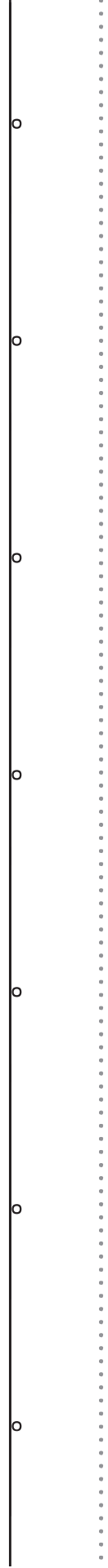
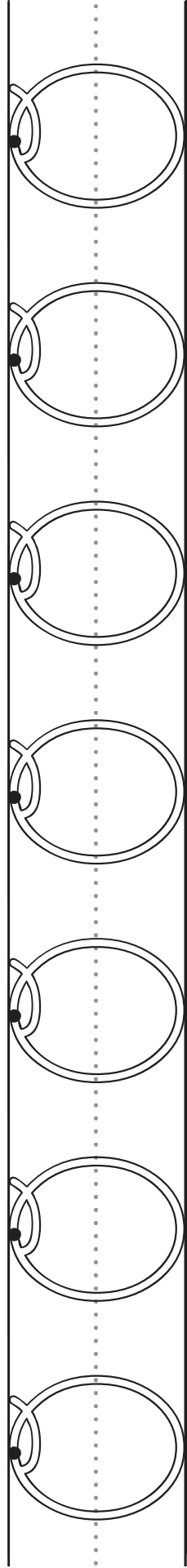
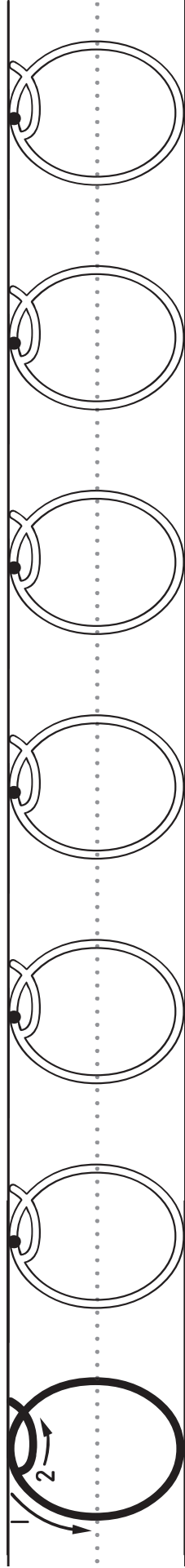

Teacher check:

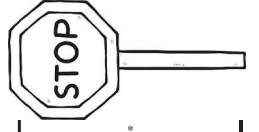

P i s p

Name: _____

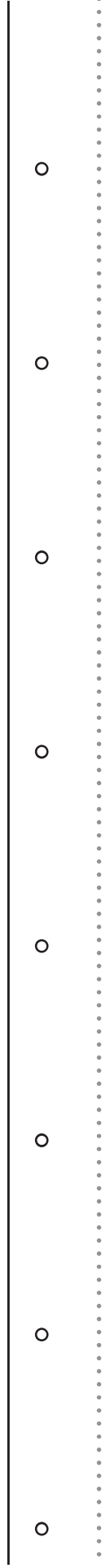
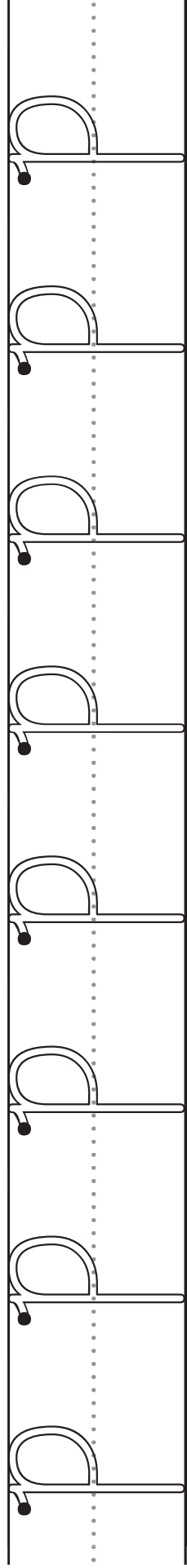
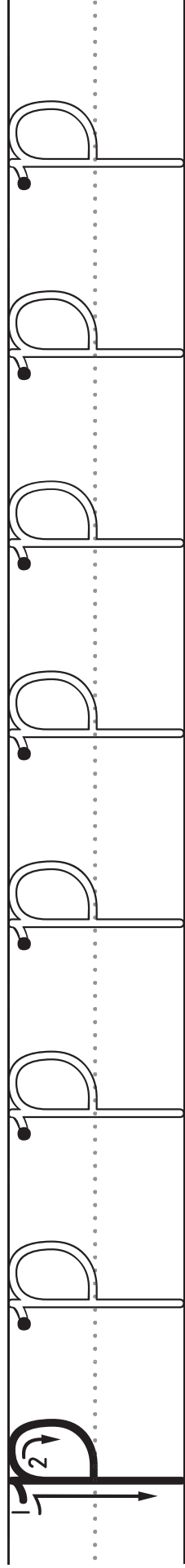

Teacher check:

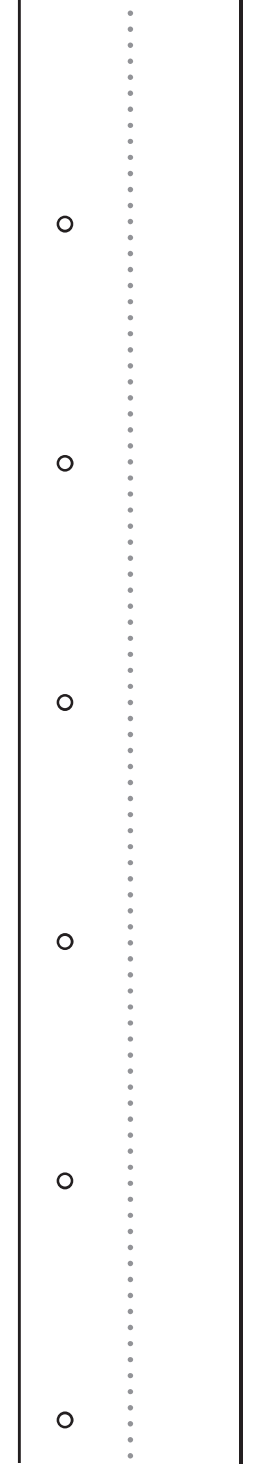
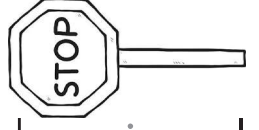

Q is 2

Name: _____

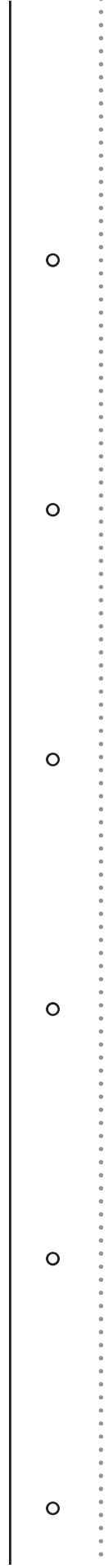
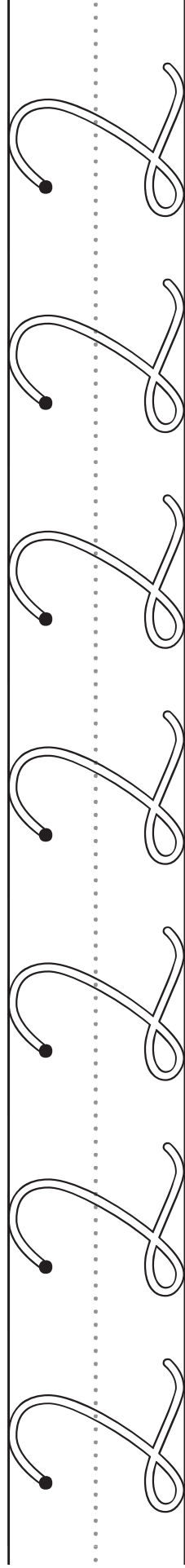
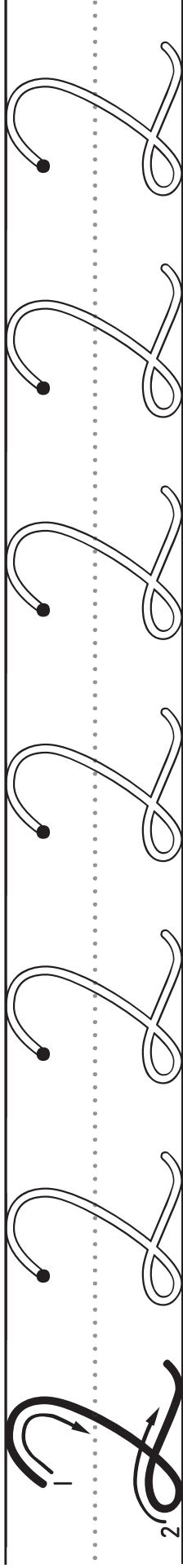

Teacher check:

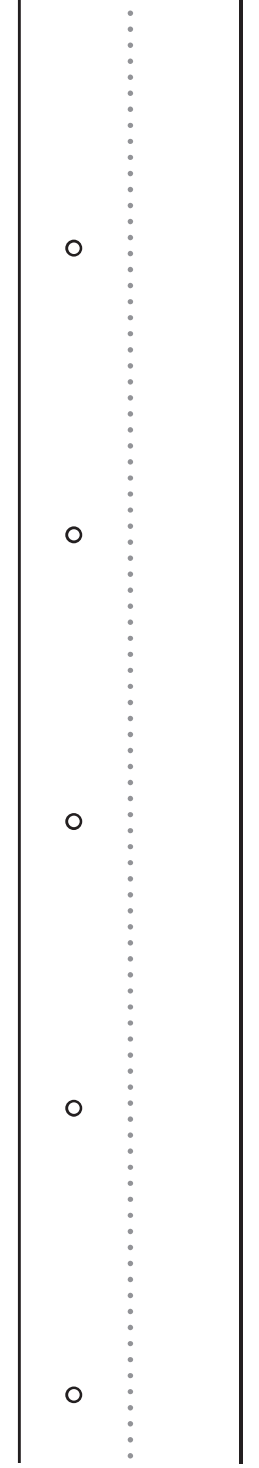
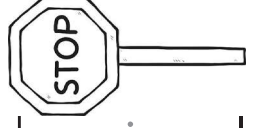

S is S

Name: _____

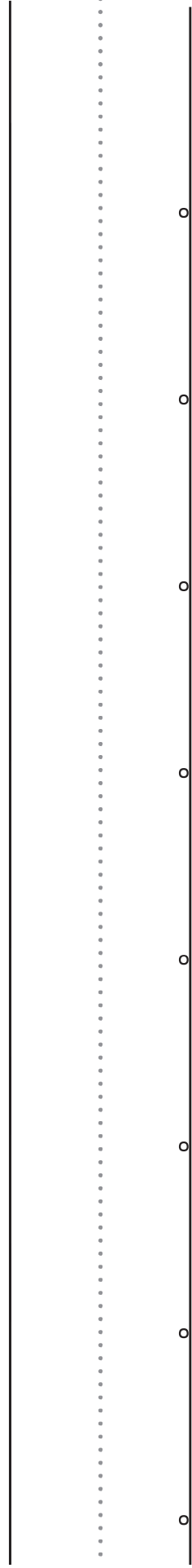
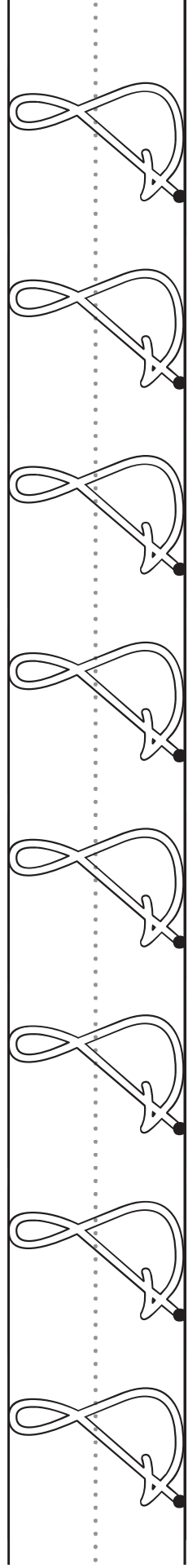
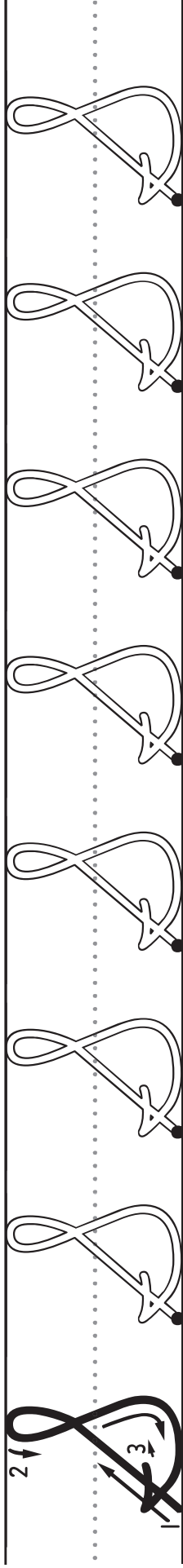

Teacher check: _____

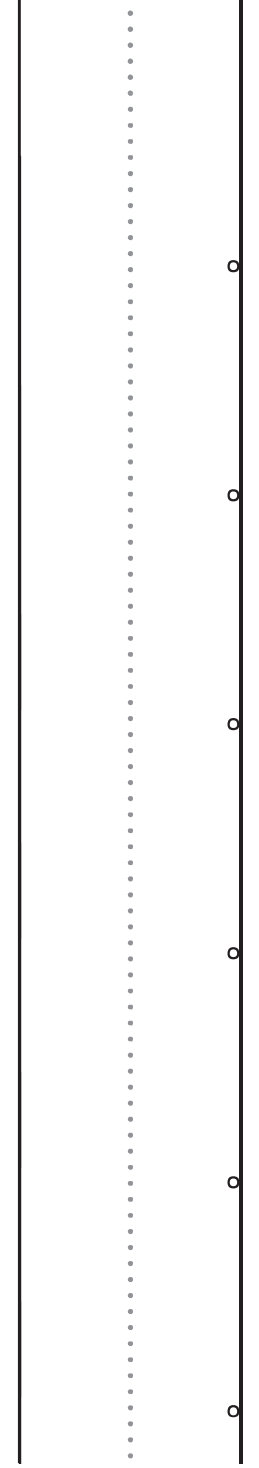
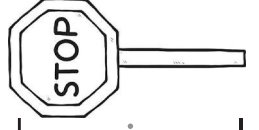

Curative S:

T i s J

Name: _____

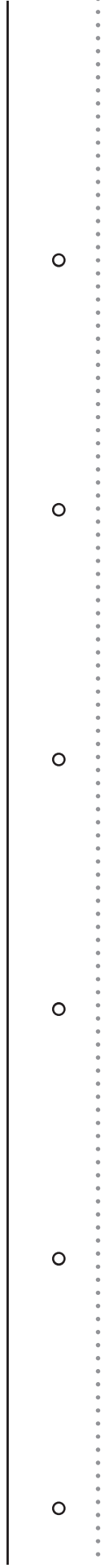
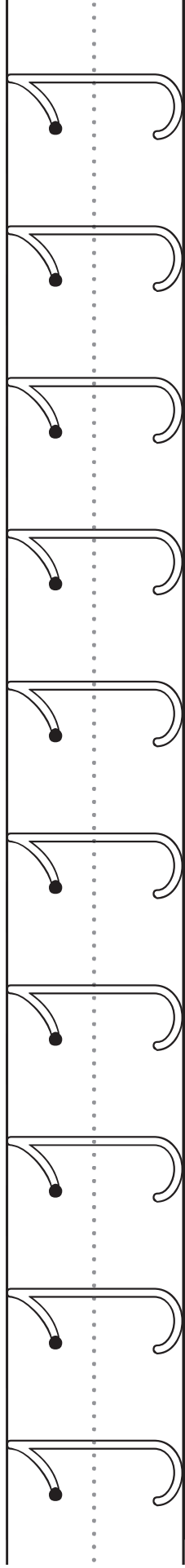
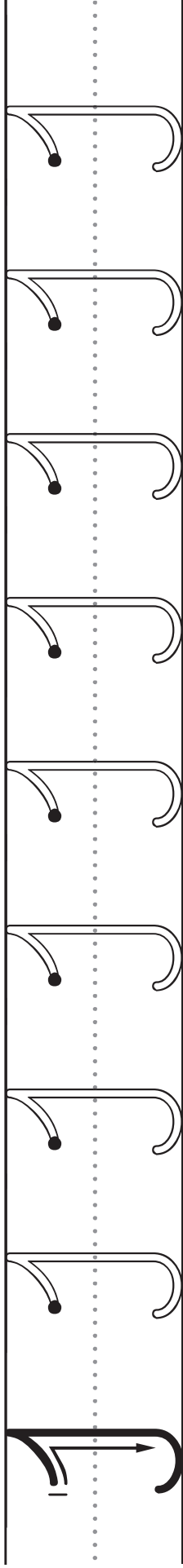

Teacher check:

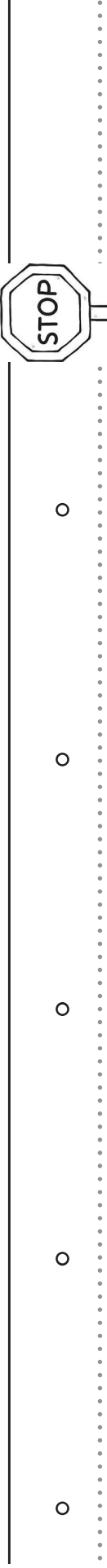
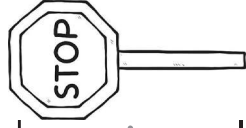

Curative T:

U is U

Name: _____

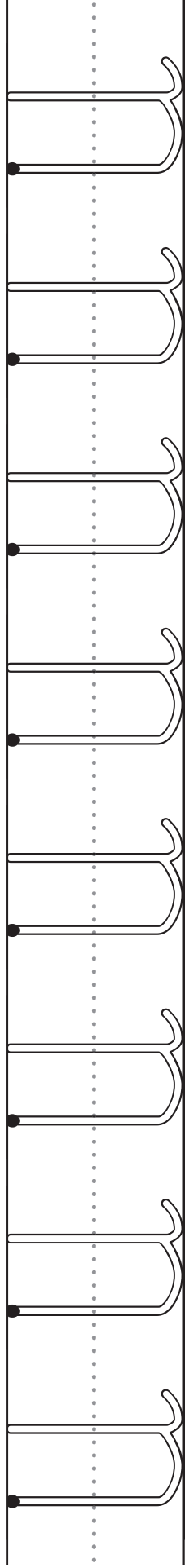
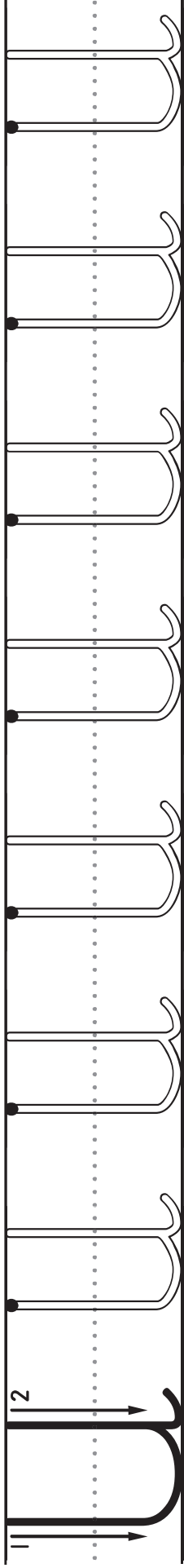

Teacher check:

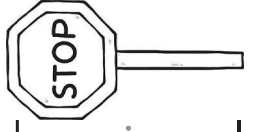

curative U:

V is V

Name: _____

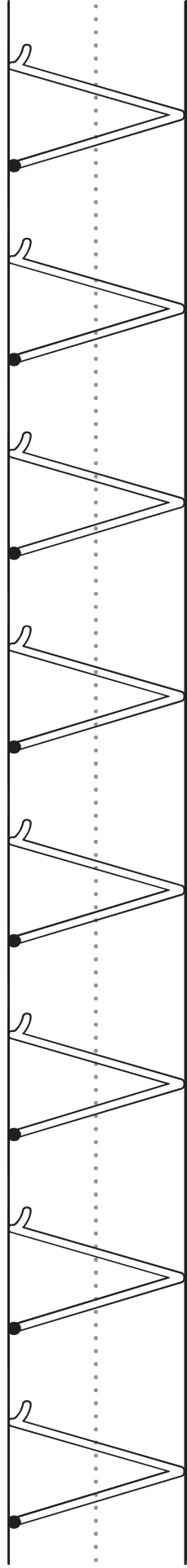
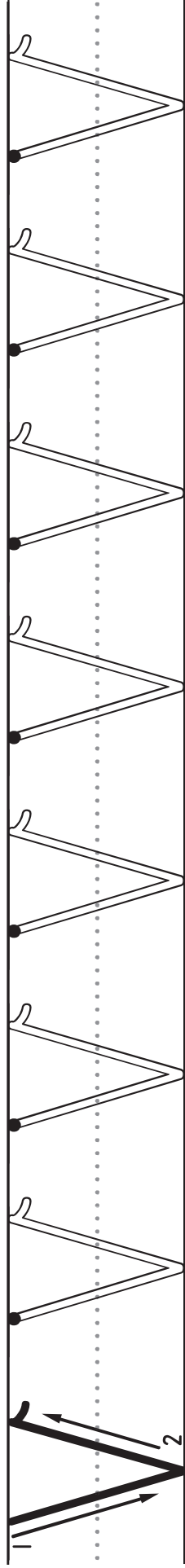

Teacher check:

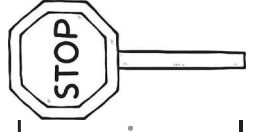

Curative V:

W i s W

Name: _____

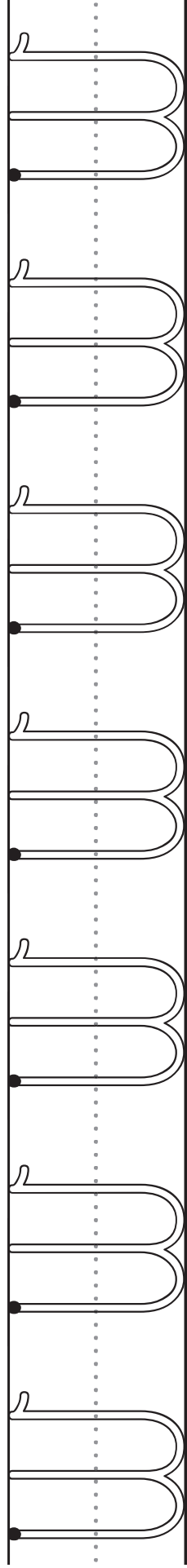
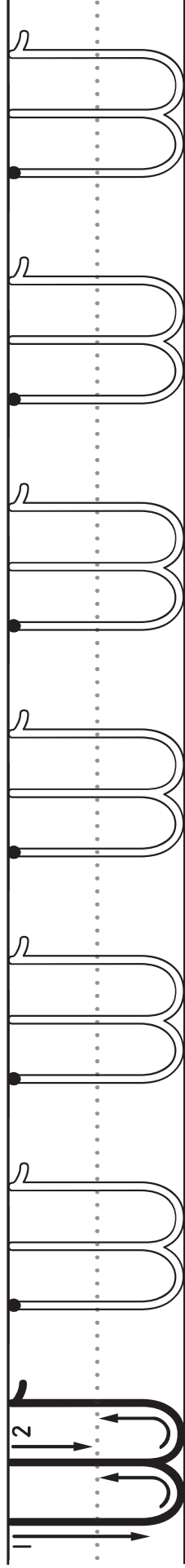

Teacher check:

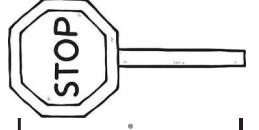

X is X

Name: _____

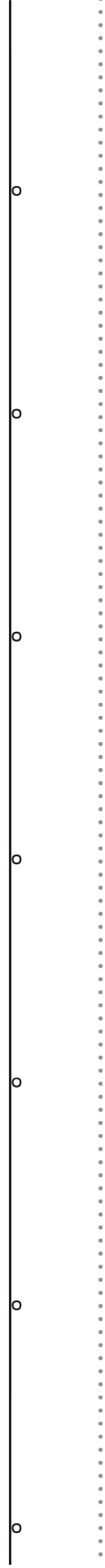
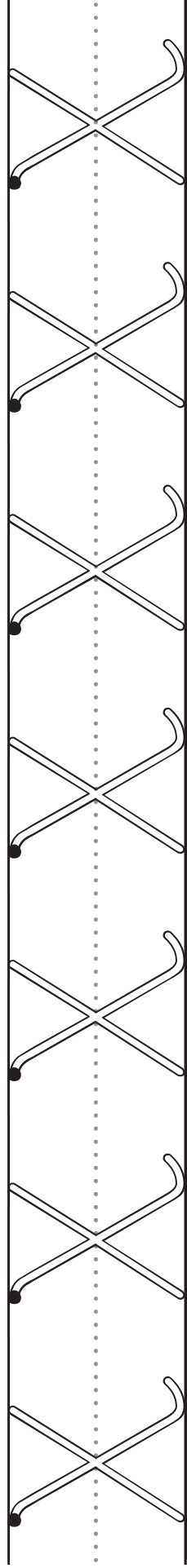
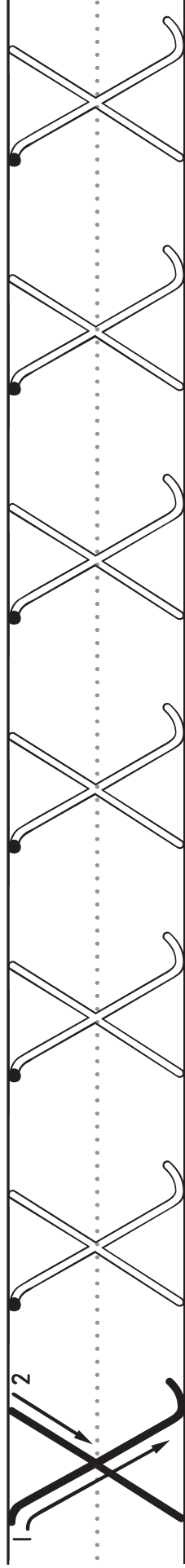

Teacher check:

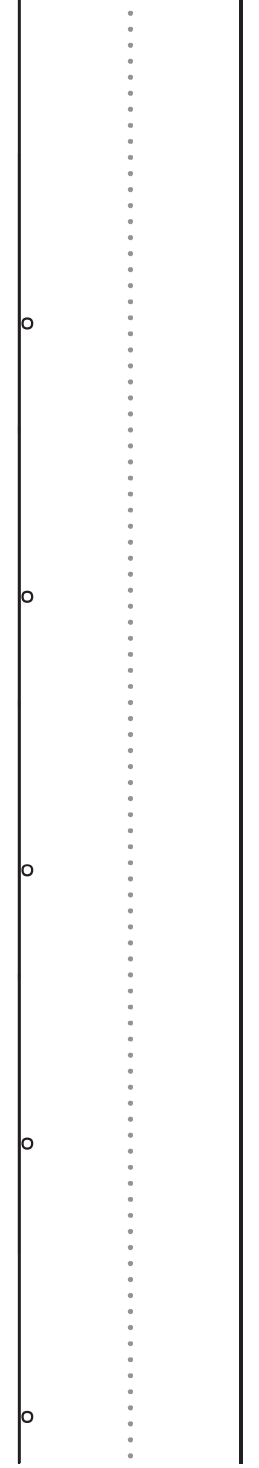
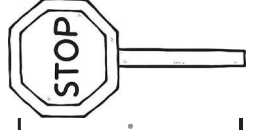

Curative X:

Y is y

Name: _____

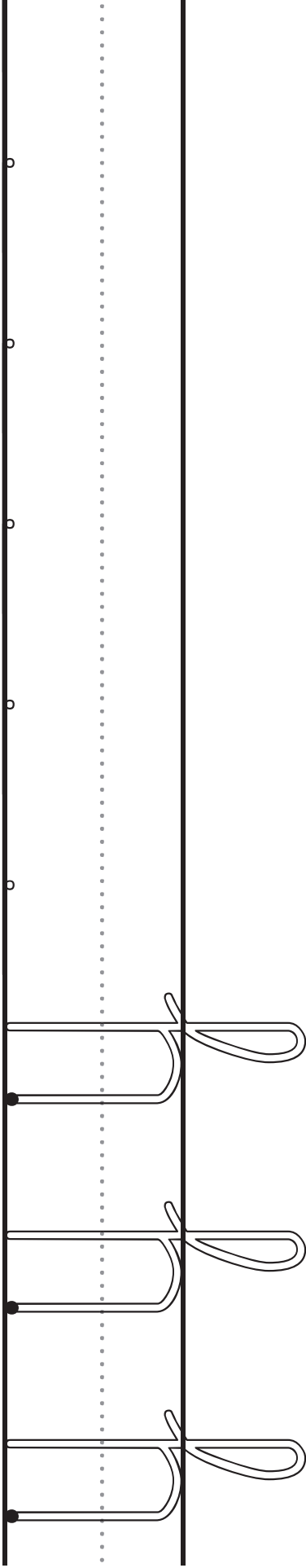
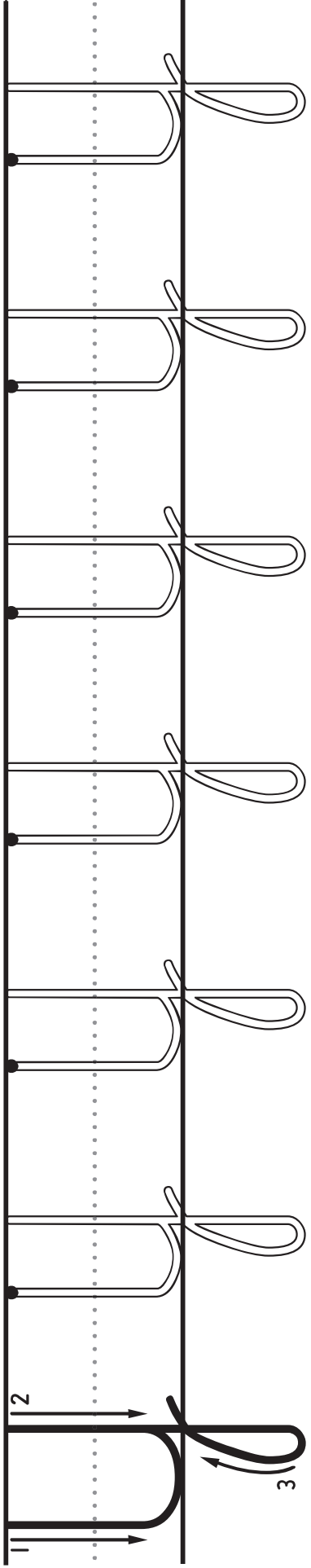

teacher check:

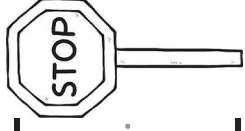

curative Y:

Z is z

Name: _____

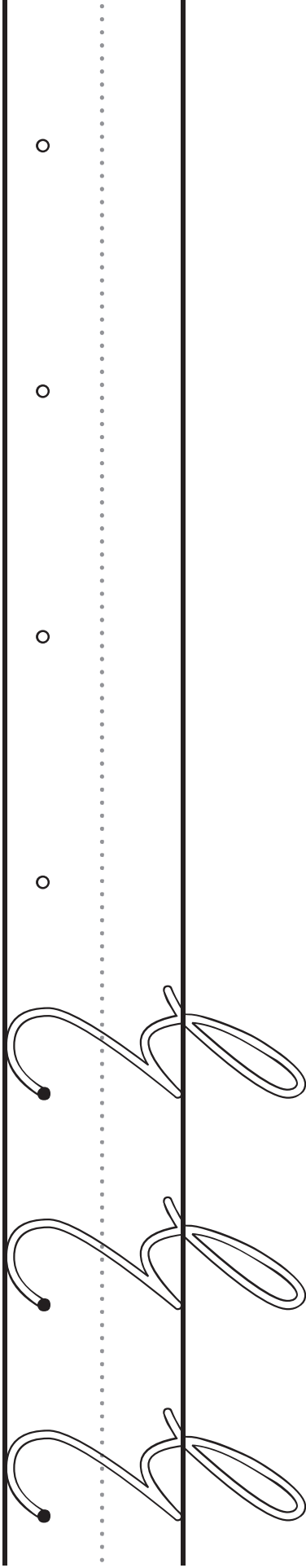
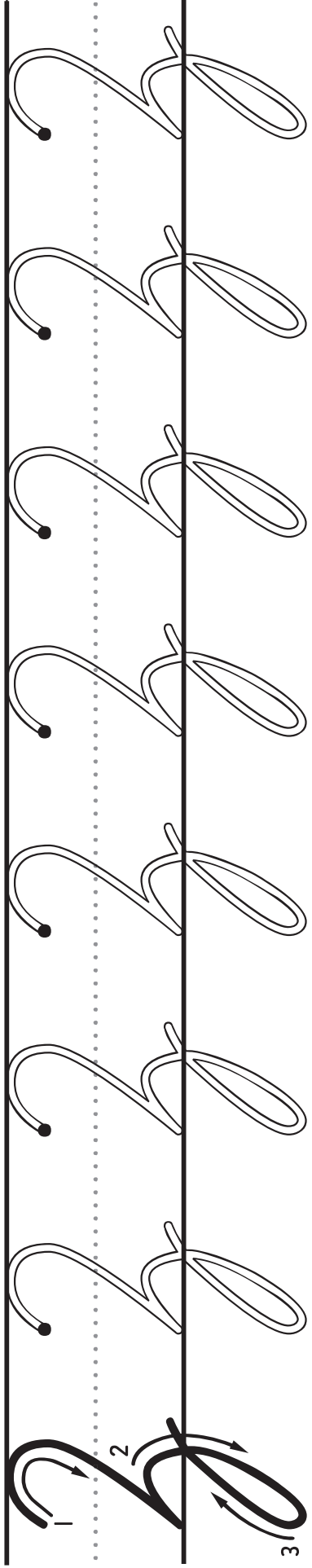

teacher check:

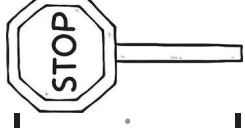

o

o

o

o

o

curly Z: □